



Hello, and welcome to the TI Precision Lab discussing intrinsic op amp noise, part 4.

In the last video we did a comprehensive noise hand calculation for a very simple op amp circuit. In a real-world circuit, these hand calculations can be long and complex. In this video we will provide several rules of thumb which can be used to simplify noise calculations by identifying the dominant source of noise and ignoring noise sources that do not make a significant contribution. Identifying the dominant source of noise will give you insight into how you can quickly and effectively improve your system's noise performance.

Too Many Variables!

resistor noise,
current noise,
voltage noise

broadband or
flicker...
multiple stages!

TEXAS INSTRUMENTS

Noise analysis can seem overwhelming to new engineers. Generally, the complete noise calculation for a simple circuit will take more than 10 steps. On more complex circuits, it can be even longer! It is also difficult to get an intuitive feel for a circuit's noise performance by doing the full calculation.

Thankfully, there is good news. In most cases it is possible to simplify the calculation by focusing on the dominant noise source or sources, and ignoring the insignificant noise sources. The trick lies in identifying what is significant and what can be ignored. This presentation covers several rules that will help you to determine if the noise source is significant or can be ignored. Knowing the dominant noise source not only simplifies your calculation, but also will highlight the factor that you need to focus on to reduce the overall noise level. For example, if current noise is the dominant factor, you may need to change from a bipolar amplifier to a CMOS amplifier. On the other hand, if resistor noise is dominant, you might want to reduce the resistor values in your circuit.

It is important to note that you cannot get much insight into what are the dominant noise sources through simulation. For example, the simulation will not let you know if resistor noise or current noise is dominant. For this reason, simulation should be used to confirm your hand calculations rather than as the only tool for noise analysis.

Now, let's look at the rules for simplification of noise analysis.

Rule 1: 3x Noise Sources are Dominant

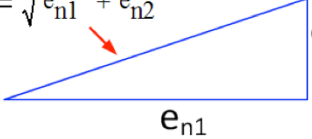
$$e_{n_total} = \sqrt{e_{n1}^2 + e_{n2}^2}$$

$$\text{Let } e_{n1} = 3e_{n2}$$

$$e_{n_total} = \sqrt{(3 \cdot e_{n2})^2 + (e_{n2})^2} = \sqrt{9 \cdot (e_{n2})^2 + (e_{n2})^2} \approx \sqrt{9 \cdot (e_{n2})^2}$$

$e_{n1} \gg e_{n2}$
 $9 \gg 1$

Example: Add $e_{n1} = 3\text{nV}$, and $e_{n2} = 1\text{nV}$

$$e_{n_total} = \sqrt{(3\text{nV})^2 + (1\text{nV})^2} = 3.16\text{nV}$$

You have probably heard the engineering rule explaining that when adding two numbers together, the smaller of the two numbers can be ignored if there is a factor of ten difference between the two values. For example, when adding 10 and 1, you can ignore the smaller of the two values and introduce a relatively small error. In this case the error would be 10%. Of course, the estimate is even better if you use a factor of 100 or 1,000. This allows the math for complex engineering problems to be greatly simplified.

The first rule of noise analysis is based on the same idea. However, remember that random uncorrelated noise sources add as the square root of the sum of the squares. So, for noise, we no longer need a factor of 10 difference between the two numbers to do the simplification. In the case of noise, a factor of 3 difference between the two terms is effectively the same as a factor of 9 because the terms are squared. For example, if a 1nV noise source is added with a 3nV noise source, the total noise is 3.16nV. **In this example, ignoring the 1nV noise source only introduces a 5% error.**

As before, increasing the factor of difference between the two terms will further improve the estimate. However, for noise analysis, a small increase in the factor will have a dramatic improvement on the accuracy of the estimate because the terms are squared. The other rules that we will discuss will compare different noise sources to determine the dominant source. Rule 1 is used as the basis for making this comparison. Let's now cover the other rules.

Rule 2: Minimize Resistor Noise

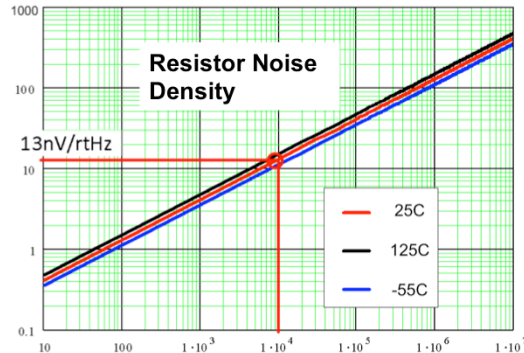
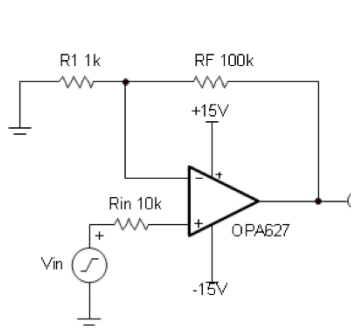

OPA627 Data Sheet

Parameter	Min	Typ	Max	Units
Noise Density (1kHz)		4.5		nV/rtHz

Resistor $e_n >$ Op-Amp e_n
 $13\text{nV}/\text{rtHz} > 4.5\text{nV}/\text{rtHz}$

TEXAS INSTRUMENTS

4

In the first noise video we learned that resistors generate noise. The second rule of a low noise system design is to keep the resistor noise much lower than the intrinsic op-amp noise. The reason is that low noise amplifiers are expensive! It doesn't make sense to use an expensive low noise amplifier with large-value resistors that dominate the noise performance. It is normally a simple design change to scale the resistors to lower values in order to reduce the overall noise response. The only real concern when reducing the resistor values is that power consumption will increase. It can be challenging to develop a low noise solution that is also low power.

Rule 3: Focus on Voltage Noise or Current Noise

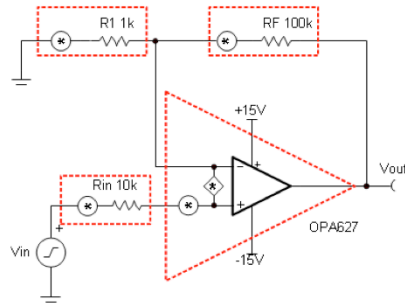

from Rin

$$e_{ni} = i_n \cdot R_{in}$$

$$e_{in} = \left(2.5 \frac{\text{fA}}{\sqrt{\text{Hz}}} \right) \cdot (10\text{k}\Omega) = 25 \frac{\text{pV}}{\sqrt{\text{Hz}}}$$

from Req

$$e_{ni} = i_n \cdot R_{eq}$$

$$e_{in} = \left(2.5 \frac{\text{fA}}{\sqrt{\text{Hz}}} \right) \cdot (1\text{k}\Omega) = 2.5 \frac{\text{pV}}{\sqrt{\text{Hz}}}$$

Voltage Noise $e_{nv} >$ Current Noise as Voltage e_{ni}
 $4.5\text{nV}/\text{rtHz} > 0.025\text{nV}/\text{rtHz}$

TEXAS INSTRUMENTS

5

The third rule of low noise design is to determine whether current noise or voltage noise is the dominant source of noise. In most cases, current noise is **not** significant on CMOS and JFET amplifiers. Most CMOS amplifiers have current noise in the fA/√Hz range, and bipolar amplifiers have current noise in the pA/√Hz range.

Current noise can be a concern if large input resistors or feedback elements are used. For resistances of 100kΩ or greater, you may need to use a CMOS or JFET amplifier. On the other hand, current noise is usually not a concern when small resistors are used. For resistances less than 1kΩ, the current noise can generally be neglected even when bipolar devices are used.

The easiest way to determine if the current noise is significant is to convert current noise spectral density to voltage noise spectral density and directly compare the two quantities. Always look at both the source resistance as well as the equivalent parallel combination of the feedback elements when doing the calculation. In this example, the input resistance is 10kΩ, and the noise current density is 2.5fA/√Hz. Just multiply the input resistance by the noise current density to calculate the equivalent voltage noise density, which turns out to be 25pV/√Hz. This is very small compared to the 4.5nV/rtHz noise voltage for the OPA627.

One objective of this step is to make sure that you are using the right type of device. Once again, you may consider a CMOS or JFET device if the feedback or source resistance is large.

Rule 4: Focus on Broadband or 1/f Noise

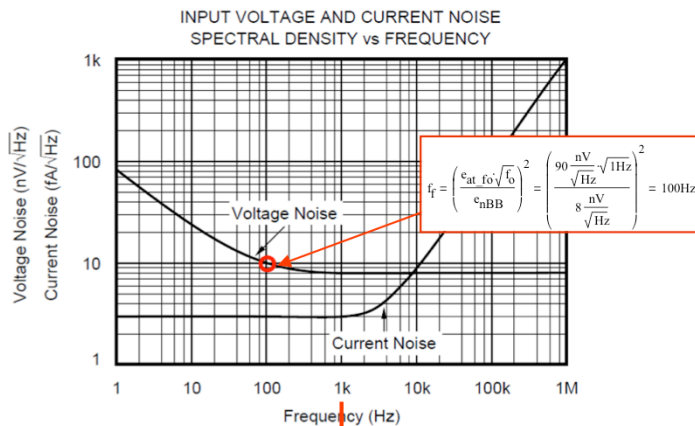

f_f is the corner frequency.
Where the 1/f noise is equal
to broadband noise.

Rule of Thumb:
Broadband noise
dominates if
 $BW > 10 \times f_f$

 TEXAS INSTRUMENTS

6

Many engineers new to noise analysis focus a lot of time and effort looking at plots of 0.1Hz to 10Hz noise or 1/f noise. Often times, however, the system bandwidth is wide and this low frequency noise is insignificant. You should consider the bandwidth of your system relative to the 1/f noise corner of the op amp. The 1/f noise corner is the point at which the 1/f noise is equal to the broadband noise. This slide shows an equation for the precise calculation of this point. However, for the purpose of this rule it is sufficient to graphically estimate the point by looking at the bend in the noise curve.

Rule 4 states that the contribution of 1/f noise can be ignored if the system bandwidth is 10 times greater than the 1/f noise corner frequency. For most precision amplifiers, the noise corner is between 1Hz and 1kHz. Thus, for systems with bandwidth greater than 10kHz you rarely need to consider 1/f noise.

Rule 5: The first stage dominates noise

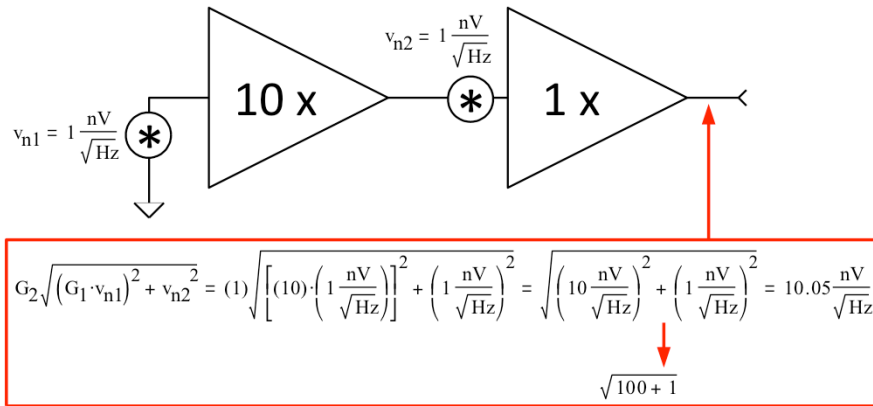

The last rule that can be used to simplify noise calculations relates to multiple stage amplifiers. It is common in analog systems to use several amplifier stages cascaded in series to achieve optimal performance. In general, it is advised to use the highest gain in the first stage. Doing this will make the error sources in the first stage dominant so that errors in subsequent stages can be safely ignored. In many cases, an expensive high precision amplifier is used in the first stage and a lower cost less precise device is used in subsequent stages to achieve excellent overall precision at a lower cost.

This example illustrates why the first stage is normally the dominant source of noise. The key to understanding this is to remember that the input noise of the first stage is multiplied by the gain of the first stage and added with the input noise of the second stage. In this example, the input referred noise for each amplifier is 1nV/√Hz, but the first op amp is in a gain of 10 while the second op amp is in a gain of 1. The output noise of the first stage is calculated by multiplying the first stage noise by the first stage gain, for a total of 10nV/√Hz. Comparing the 10nV/√Hz output noise from the first stage to the 1nV/√Hz input noise from the second stage, you can easily see that the first stage is dominant and you can ignore noise from the second stage. Take care to make sure that the first stage gain is large enough to ensure that the output noise from the first stage is at least three times greater than the input of the second stage.

Rule 2: Voltage Noise vs. Resistor Noise

$$e_{nr} = \sqrt{4k_n \cdot T_n \cdot R_{eq}} = \sqrt{4(1.38 \cdot 10^{-23}) \cdot (298) \cdot (100)} = 1.3 \frac{\text{nV}}{\sqrt{\text{Hz}}}$$

$$e_{nv} = 4.5 \frac{\text{nV}}{\sqrt{\text{Hz}}} \quad \text{from data sheet}$$

Note $e_{nv} > 3 \cdot e_{nr}$ so ignore resistor noise

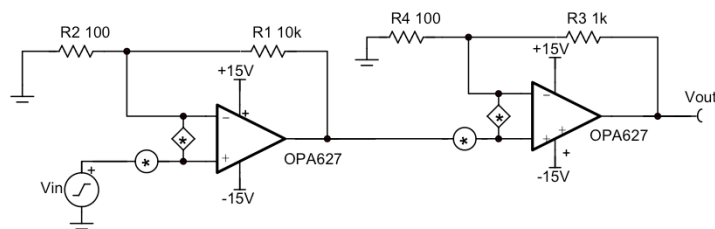

TEXAS INSTRUMENTS

8

Let's take a look at a few real world examples that illustrate the Rules of Thumb.

Let's start with Rule 2: minimize resistor noise. We can calculate the precise resistor noise of this circuit from the equivalent feedback resistors, or we can use the graph. Generally, I just use the graph because it's easy and we only need an approximate value for the noise. Compare the resistor noise to the op amp voltage noise from the data sheet. In this example, the resistor noise is 1.3nV/√Hz and the op amp voltage noise is 4.5nV/√Hz. Therefore, the op amp noise is about 3.5 times larger than the resistor thermal noise. This is good, because we normally want the op amp noise to be dominant. We could further reduce the thermal noise by decreasing the feedback resistors, but it would have little effect on the overall noise. Also, reducing the feedback resistors will increase the systems power dissipation.

Remember, one of the main goals of this rule is to simplify the final noise calculation. In this case we do not need to consider the resistor noise, because the amplifier noise is dominant.

Rule 3: Voltage Noise vs. Current Noise

$$e_{ni} = i_{bn} \cdot R_{eq} = 1.6 \frac{\text{fA}}{\sqrt{\text{Hz}}} \cdot 100\Omega = 0.16 \frac{\text{pV}}{\sqrt{\text{Hz}}}$$

$$e_{nv} = 4.5 \frac{\text{nV}}{\sqrt{\text{Hz}}} \quad \text{from data sheet}$$

Note $e_{nv} > 3 \cdot e_{ni}$ so ignore current noise

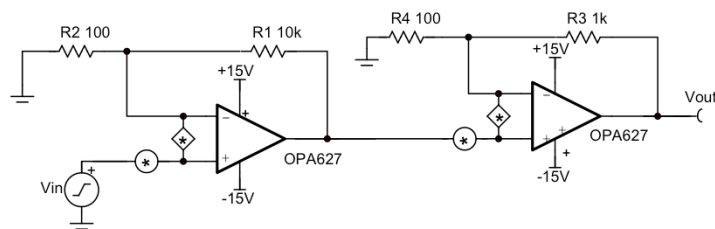

TEXAS INSTRUMENTS

9

Rule 3 enables us to check if op amp voltage noise or current noise is dominant.

The check is done by simply multiplying the current noise by the equivalent feedback resistance. In this example, the device has a JFET input so the current noise is very low at 1.6fA/√Hz. In general, for current noise in this low range it is very unlikely that current noise will be a significant contributor. However, in this example we do the calculation for completeness. The current noise multiplied by the equivalent resistance translates to an equivalent 0.16pV/√Hz of voltage noise. This is significantly smaller than the 4.5nV/√Hz of amplifier voltage noise, so the current noise can be ignored. This test is much more important if bipolar amplifiers are used or if very large feedback or source resistance is used.

Rule 4: Broadband Noise vs. 1/f Noise

$$f_c = \frac{GBW}{G_n} = \frac{16\text{MHz}}{101} = 158\text{kHz}$$

$$BW_n = K_n \cdot f_c = 1.57 \cdot (158\text{kHz}) = 249\text{kHz}$$

$$BW_n > 10 \cdot f_f$$

$$249\text{kHz} > 10 \cdot 1\text{kHz}$$

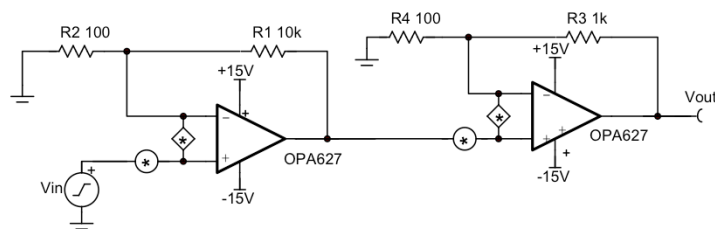
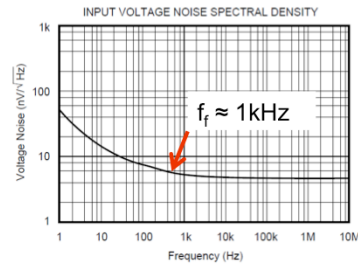

TEXAS INSTRUMENTS

10

Now let's see if we can ignore the 1/f noise. In this example, the 1/f noise corner can be graphically estimated to be about 1kHz. Of course, you could use the equation given earlier to find the precise location of the noise corner but the estimate is sufficient when using Rule 4. After finding the noise corner, we need to know the noise bandwidth. Using the gain bandwidth product and the noise gain, we find that the bandwidth is 160kHz. The noise bandwidth is then calculated with the factor of 1.57 for a first order brick wall filter correction, as discussed in a previous video.

The noise bandwidth comes out to 249kHz, which is **much** higher than the noise corner at 1kHz. Thus, for this example we can ignore the 1/f noise. Besides simplifying the calculation, this rule keeps you focused on what is important. For example, the 0.1Hz to 10Hz noise waveform is really just a way of looking at the 1/f noise. This curve is not relevant if the broadband noise is dominant.

Rule 5: Is the First Stage Dominant?

$$e_{n1} := 4.5 \frac{\text{nV}}{\sqrt{\text{Hz}}}$$

$$e_{n2} := 4.5 \frac{\text{nV}}{\sqrt{\text{Hz}}}$$

Comparing output noise from first stage to input noise of second stage.

$$G_{n1} = 101$$

$$G_{n2} = 11$$

$$455 \frac{\text{nV}}{\sqrt{\text{Hz}}} \gg 4.5 \frac{\text{nV}}{\sqrt{\text{Hz}}}$$

Output noise of first stage

$$e_{n1} \cdot G_{n1} = \left(4.5 \frac{\text{nV}}{\sqrt{\text{Hz}}} \right) \cdot (101) = 455 \frac{\text{nV}}{\sqrt{\text{Hz}}}$$

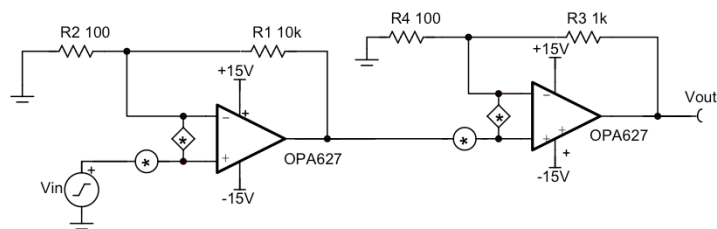

TEXAS INSTRUMENTS

11

The fifth rule tells us that the first stage noise is normally dominant. Normally this will be the case, but it is always best to check if the first stage gain is low or if the following stages use amplifiers with higher noise.

In this case the first stage's noise gain is 101 and a low noise amplifier is being used for both stages. So, it is likely that the input stage noise will be dominant. Let's compare the first stage output noise with the second stage input noise. In this case, you can see that the output noise from the first stage is 101 times greater than the input noise to the second stage. Thus, you can safely ignore the noise from the second stage to simplify your calculations.

Simple Hand Calculation – Total Noise

$$f_c = \frac{GBW}{G_n} = \frac{16\text{MHz}}{101} = 158\text{kHz}$$

$$BW_n = K_n \cdot f_c = 1.57 \cdot (158\text{kHz}) = 249\text{kHz}$$

$$E_{n_in_simple} = e_n \cdot \sqrt{BW_n} = \left(4.5 \frac{\text{nV}}{\sqrt{\text{Hz}}} \right) \cdot \sqrt{249\text{kHz}} = 2.245\mu\text{Vrms}$$

$$E_{n_out_simple} = G_{n1} \cdot G_{n2} \cdot E_{n_in_simple} = (11) \cdot (101) \cdot (2.245\mu\text{Vrms}) = 2.5\text{mVrms}$$

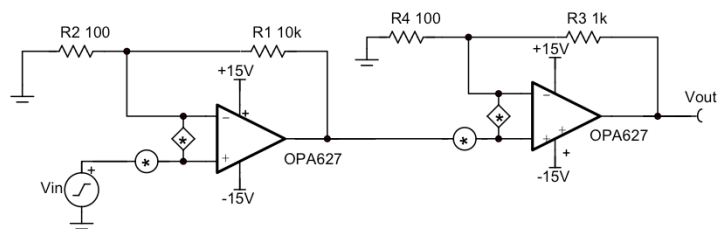

TEXAS INSTRUMENTS

12

Now that we have applied all the rules, let's do the simplified calculation for the entire system. In this example we can ignore current noise, 1/f noise, resistor noise, and second stage noise. The only factor we need to consider is the voltage noise of the input stage. To find the system output noise, first find the noise bandwidth of the input stage. Second, use the broadband noise equation to calculate the RMS input noise, and then multiply this by the total gain for both stages. In this example, the total noise is 2.5mV rms.

So this was a pretty simple calculation, but how accurate is it?

Doing It the Hard Way!

OPA627 Noise, Input Stage

Thermal noise calculation

$$k_B := 1.38 \cdot 10^{-23} \text{ J/K} \quad T_A := 273 + 25 \quad R_{N1} := 100$$

$$e_{n,T} := \sqrt{4k_B T_A R_{N1}} = 1.283 \times 10^{-9} \frac{\text{V}}{\sqrt{\text{Hz}}}$$

op-amp current and voltage noise

$$e_{n,opa} := 4.5 \times 10^{-9} \frac{\text{V}}{\sqrt{\text{Hz}}} \quad \text{From Data Sheet}$$

$$i_b := 1.6 \times 10^{-15} \frac{\text{A}}{\sqrt{\text{Hz}}} \quad \text{From Data Sheet}$$

$$e_{n,i} := R_{N1} i_b = 1.60 \times 10^{-15} \frac{\text{V}}{\sqrt{\text{Hz}}}$$

Add thermal noise and voltage noise calculation

$$e_{n,total1} := \sqrt{e_{n,T}^2 + e_{n,opa}^2 + e_{n,i}^2} = 4.679 \times 10^{-9}$$

Gain from two stage amp

$$G_{N1} := 101 \quad G_{N2} := 11$$

GBW := 16·10⁶ From Data Sheet

Closed loop bandwidth (-3dB)

$$f_c := \frac{GBW}{G_{N1}} = 158.416 \times 10^3 \text{ Hz}$$

Noise bandwidth (-3dB)

$$BW_{N1} := 1.57 f_c = 248.713 \times 10^3 \text{ Hz}$$

$$E_{n1} := e_{n,total1} \sqrt{BW_{N1}} = 2.334 \times 10^{-6} \text{ Vrms RTI}$$

1/f noise RTI

$$e_{n1f} := 50 \cdot 10^{-9} \quad f_c := 1 \text{ Hz}$$

$$e_{n1normal} := e_{n1f} \sqrt{f_c}$$

$$E_{n1flicker} := e_{n1normal} \sqrt{\ln\left(\frac{f_c}{0.1}\right)} = 188.915 \times 10^{-9} \text{ Vrms RTI}$$

Total noise including 1/f RTI

$$E_{n1} := \sqrt{E_{n1}^2 + E_{n1flicker}^2} = 2.341 \times 10^{-6} \text{ Vrms}$$

Total rms noise from stage 1 RTD

$$E_{n_out1} := G_{N1} G_{N2} E_{n1} = 2.6 \times 10^{-3} \text{ Vrms}$$

OPA627 Noise, Output Stage

Thermal noise calculation

$$k_B := 1.38 \cdot 10^{-23} \text{ J/K} \quad T_A := 273 + 25 \quad R_{N2} := 100$$

$$e_{n,T} := \sqrt{4k_B T_A R_{N2}} = 1.283 \times 10^{-9} \frac{\text{V}}{\sqrt{\text{Hz}}}$$

op-amp current and voltage noise

$$e_{n,opa} := 4.5 \times 10^{-9} \frac{\text{V}}{\sqrt{\text{Hz}}} \quad \text{From Data Sheet}$$

$$i_b := 1.6 \times 10^{-15} \frac{\text{A}}{\sqrt{\text{Hz}}} \quad \text{From Data Sheet}$$

$$e_{n,i} := R_{N2} i_b = 1.60 \times 10^{-15} \frac{\text{V}}{\sqrt{\text{Hz}}}$$

Add thermal noise and voltage noise calculation

$$e_{n,total2} := \sqrt{e_{n,T}^2 + e_{n,opa}^2 + e_{n,i}^2} = 4.679 \times 10^{-9}$$

Gain from two stage amp

$$G_{N1} := 101 \quad G_{N2} := 11$$

GBW := 16·10⁶ From Data Sheet

Closed loop bandwidth (-3dB)

$$f_c := \frac{GBW}{G_{N2}} = 1.455 \times 10^6 \text{ Hz}$$

Noise bandwidth (-3dB)

$$BW_{N2} := 1.57 f_c = 2.284 \times 10^6 \text{ Hz}$$

$$E_{n2} := e_{n,total2} \sqrt{BW_{N2}} = 7.071 \times 10^{-6} \text{ Vrms RTI stage 2}$$

1/f noise RTI

$$e_{n2f} := 50 \cdot 10^{-9} \quad f_c := 1 \text{ Hz}$$

$$e_{n2normal} := e_{n2f} \sqrt{f_c}$$

$$E_{n2flicker} := e_{n2normal} \sqrt{\ln\left(\frac{f_c}{0.1}\right)} = 203.657 \times 10^{-9} \text{ Vrms RTI}$$

Total noise RTI stage 2

$$E_{n2} := \sqrt{E_{n2}^2 + E_{n2flicker}^2} = 7.074 \times 10^{-6} \text{ Vrms}$$

Total rms noise from stage 2 RTD

$$E_{n_out2} := G_{N1} G_{N2} E_{n2} = 77.81 \times 10^{-6} \text{ Vrms}$$

$$E_{n_out2} := 77.81 \cdot 10^{-6} \text{ Vrms}$$

Output noise of stage 1 combined with input noise of stage 2.

$$E_{n_out1} := 2.6 \times 10^{-3} \text{ Vrms}$$

$$E_{n_out_total} := \sqrt{E_{n_out1}^2 + E_{n_out2}^2} = 2.6 \times 10^{-3} \text{ Vrms}$$

Compare simplified calculation from the previous page!

$$E_{n_out_simple} := 2.50 \cdot 10^{-3} \text{ Vrms}$$

This slide shows the how to do the full calculation considering all the factors. Notice that the final result of 2.59mV rms is **very** close to the simplified result of 2.5mV rms. Perhaps more importantly, applying the rules helped us to gain insight into the key factor affecting the noise performance of this system – the first stage input voltage noise. Now we know what can be modified to reduce the overall system noise.

How to Reduce Noise

- Select a low noise amplifier
 - Consider both current and voltage noise
 - Consider low and high frequency noise
- Select the appropriate feedback resistors
 - Low resistance for low noise
- Limit the system bandwidth

Here are the most common system factors which can be adjusted to reduce the total noise. Remember, usually one of these factors is the main contributor to overall noise!

Assuming the amplifier noise is the circuit limitation, you can choose a lower noise device to get better performance. Make sure that you consider both current noise and voltage noise when making the selection. Also, make sure that the feedback and source resistance used in your application is low enough so that the resistor noise is not a significant factor. Finally, always limit your bandwidth to the minimum bandwidth that is acceptable for your system. Limiting the bandwidth is often the easiest way to reduce your total noise. Let's consider an example.

With and Without a Filter!

$$f_1 = \frac{1}{2 \cdot \pi \cdot 10\text{k}\Omega \cdot 1\text{nF}} = 15.9\text{kHz}$$

$$f_2 = \frac{1}{2 \cdot \pi \cdot 1\text{k}\Omega \cdot 10\text{nF}} = 15.9\text{kHz}$$

$$BW_n = 1.57 \cdot (15.9\text{kHz}) = 25\text{kHz}$$

$$E_{n_with_filter} = 101 \cdot 11 \cdot \left(4.5 \frac{\text{nV}}{\sqrt{\text{Hz}}} \right) \cdot \sqrt{25\text{kHz}} = 790\mu\text{V rms}$$

$$E_{n_no_filter} = 2.5\text{mV rms} \quad \text{with } f_c = 158\text{kHz}$$

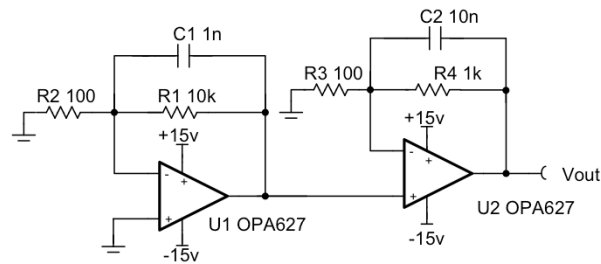

TEXAS INSTRUMENTS

15

This slide shows the effect of limiting the bandwidth from the unfiltered bandwidth of 158kHz to a filtered bandwidth of 15.8kHz. The unfiltered circuit is the same circuit that we have been looking at throughout this presentation. The filtered circuit simply uses two feedback capacitors, C1 and C2, to set the bandwidth to of each stage to 15.8kHz. Using the bandwidth, you can find the noise bandwidth and total noise using the same methods already described. In this example, the noise was reduced from 2.5mV rms to 790 μ V rms with filtering.

**Thanks for your time!
Please try the quiz.**

16



That concludes this video – thank you for watching! Please try the quiz to check your understanding of this video’s content.

Noise 4

Multiple Choice Quiz

TI Precision Labs – Op Amps



Quiz: Noise 4

1. When adding two noise sources it is permissible to ignore the smaller source if the larger source is _____ times greater than the smaller.

- a. Two
- b. Three
- c. Five
- d. Ten

2. It is important to keep _____.

- a. Op amp noise at least three times greater than resistor noise.
- b. Op amp noise at least three times smaller than resistor noise.

3. (T/F) Current noise from CMOS amplifiers is rarely a factor in determining the total noise.

- a. True
- b. False

Quiz: Noise 4

4. How do you determine if current noise is a factor in determining the total noise?

- a. Compare current noise to bias current
- b. Convert current noise to voltage noise and compare to op amp voltage noise.
- c. Current noise is only a factor at low temperature
- d. Current noise is only a factor if low source impedance is used.

5. The equivalent feedback impedance for an op amp is 100 ohms. Assuming a bipolar op amp is used, will current noise be a factor in determining total noise?

- a. It is very unlikely that current noise will be a factor.
- b. It is likely that current noise will be a factor.

6. How can you quickly find the 1/f noise corner on a noise spectral density plot?

- a. Use the gain bandwidth product and closed loop gain.
- b. Look for the bend in the curve.
- c. This information is normally given in the specification table.
- d. Integrate the noise over frequency and divide by Avogadro's number

Quiz: Noise 4

7. Assume the bandwidth of an amplifier is 10kHz and the noise corner is 200Hz. Can you ignore 1/f noise?

- a. Yes
- b. No
- c. This depends on the input resistance.

8. For a multiple stage amplifier, it is recommended that you have the highest gain in the ____.

- a. Input stage
- b. Output stage

Noise 4

Multiple Choice Quiz: Solutions

TI Precision Labs – Op Amps

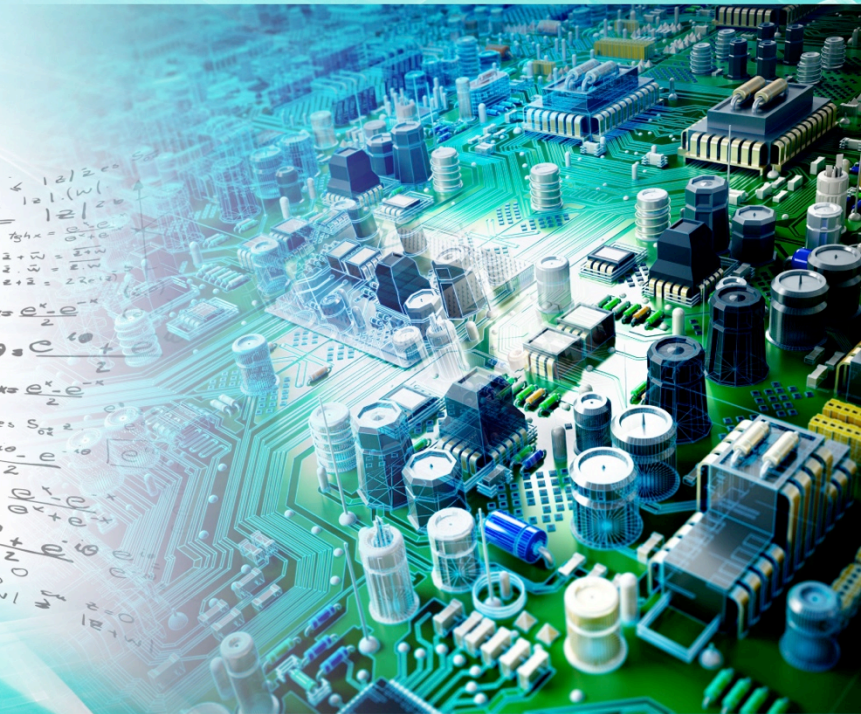

Quiz: Noise 4

1. When adding two noise sources it is permissible to ignore the smaller source if the larger source is _____ times greater than the smaller.

- a. Two
- b. Three
- c. Five
- d. Ten

2. It is important to keep _____.

- a. Op amp noise at least three times greater than resistor noise.
- b. Op amp noise at least three times smaller than resistor noise.

3. (T/F) Current noise from CMOS amplifiers is rarely a factor in determining the total noise.

- a. True
- b. False

Quiz: Noise 4

4. How do you determine if current noise is a factor in determining the total noise?

- a. Compare current noise to bias current
- b. Convert current noise to voltage noise and compare to op amp voltage noise.
- c. Current noise is only a factor at low temperature
- d. Current noise is only a factor if low source impedance is used.

5. The equivalent feedback impedance for an op amp is 100 ohms. Assuming a bipolar op amp is used, will current noise be a factor in determining total noise?

- a. It is very unlikely that current noise will be a factor.
- b. It is likely that current noise will be a factor.

6. How can you quickly find the 1/f noise corner on a noise spectral density plot?

- a. Use the gain bandwidth product and closed loop gain.
- b. Look for the bend in the curve.
- c. This information is normally given in the specification table.
- d. Integrate the noise over frequency and divide by Avogadro's number

Quiz: Noise 4

7. Assume the bandwidth of an amplifier is 10kHz and the noise corner is 200Hz. Can you ignore 1/f noise?

- a. Yes
- b. No
- c. This depends on the input resistance.

8. For a multiple stage amplifier, it is recommended that you have the highest gain in the ____.

- a. Input stage
- b. Output stage

Noise 4

Exercises

TI Precision Labs – Op Amps



1. Is current noise or voltage noise dominant for the circuit below?
2. Is 1/f or broadband dominant?
3. Is resistor or op amp voltage noise dominant?
4. Calculate the total noise using appropriate simplifications.

ELECTRICAL CHARACTERISTICS: $V_S = \pm 2.25\text{ V}$ to $\pm 4\text{ V}$ ($V_S = +4.5\text{ V}$ to $+8\text{ V}$)

At $T_A = +25^\circ\text{C}$, $V_{CM} = V_{OUT} = V_S / 2$, and $R_{LOAD} = 10\text{ k}\Omega$ connected to $V_S / 2$, unless otherwise noted.

PARAMETER	TEST CONDITIONS	OPA192			UNIT
		MIN	TYP	MAX	
NOISE					
E_n Input voltage noise	$(V-) - 0.1\text{ V} < V_{CM} < (V+) - 3\text{ V}$, $f = 0.1\text{ Hz to } 10\text{ Hz}$		1.30		μV_{PP}
	$(V+) - 1.5\text{ V} < V_{CM} < (V+) + 0.1\text{ V}$, $f = 0.1\text{ Hz to } 10\text{ Hz}$		4		μV_{PP}
e_n Input voltage noise density	$(V-) - 0.1\text{ V} < V_{CM} < (V+) - 3\text{ V}$	$f = 100\text{ Hz}$		10.5	$\text{nV}/\sqrt{\text{Hz}}$
		$f = 1\text{ kHz}$		5.5	$\text{nV}/\sqrt{\text{Hz}}$
	$(V+) - 1.5\text{ V} < V_{CM} < (V+) + 0.1\text{ V}$	$f = 100\text{ Hz}$		32	$\text{nV}/\sqrt{\text{Hz}}$
		$f = 1\text{ kHz}$		12.5	$\text{nV}/\sqrt{\text{Hz}}$
i_n Input current noise density	$f = 1\text{ kHz}$		1.5		$\text{fA}/\sqrt{\text{Hz}}$
FREQUENCY RESPONSE					
GBW Unity gain bandwidth			10		MHz

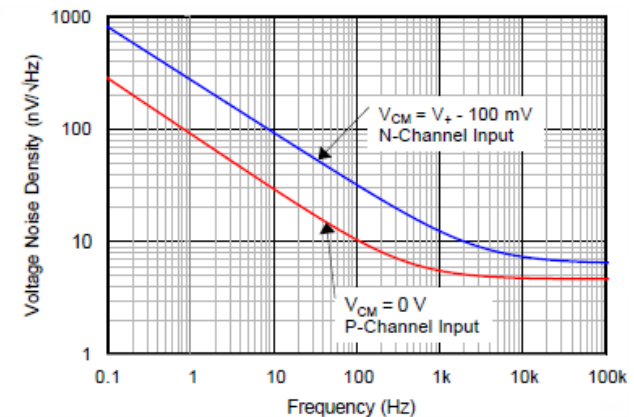
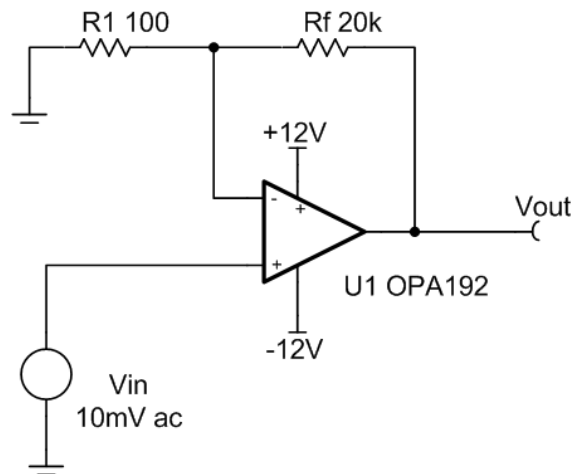

Figure 17. INPUT VOLTAGE NOISE SPECTRAL DENSITY vs FREQUENCY

5. Is current noise or voltage noise dominant for the circuit below?
6. Is 1/f or broadband dominant?
7. Is resistor or op amp voltage noise dominant?
8. Calculate the total rms noise at the output.

ELECTRICAL CHARACTERISTICS: $V_S = \pm 2.25V$ to $\pm 18V$

BOLDFACE limits apply over the specified temperature range, $T_A = -40^\circ C$ to $+125^\circ C$.

At $T_A = +25^\circ C$, $R_L = 10k\Omega$ connected to midsupply, $V_{CM} = V_{OUT} =$ midsupply, unless otherwise noted.

PARAMETER	CONDITIONS	Standard Grade OPA211AI, OPA2211AI			High Grade OPA211I(1)			UNIT
		MIN	TYP	MAX	MIN	TYP	MAX	
NOISE								
Input Voltage Noise	e_n		80		80			nV _{pp}
Input Voltage Noise Density			2		2			nV/ \sqrt{Hz}
		$f = 100Hz$	1.4		1.4			nV/ \sqrt{Hz}
		$f = 1kHz$	1.1		1.1			nV/ \sqrt{Hz}
Input Current Noise Density	i_n		3.2		3.2			pA/ \sqrt{Hz}
		$f = 1kHz$	1.7		1.7			pA/ \sqrt{Hz}
FREQUENCY RESPONSE								
Gain-Bandwidth Product	GBW	$G = 100$	80		80			MHz
		$G = 1$	45		45			MHz

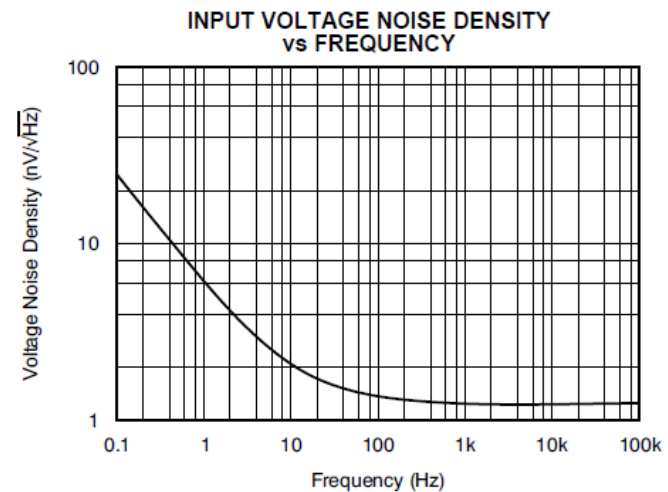
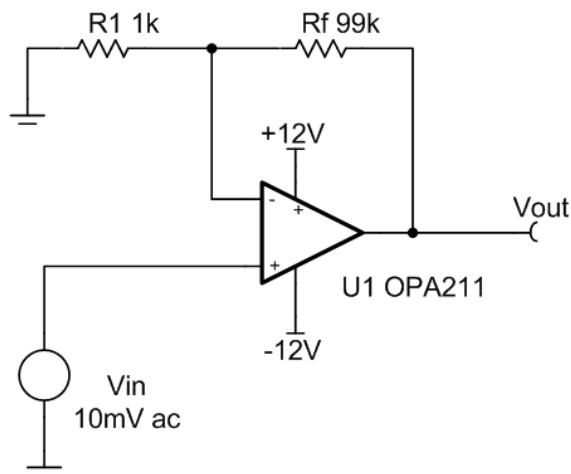

9. Is the input or output stage dominant?
10. Is current noise or voltage noise dominant for the circuit below?
11. Is 1/f or broadband dominant?
12. Is resistor or op amp voltage noise dominant?
13. Calculate the total noise using appropriate simplifications.

ELECTRICAL CHARACTERISTICS:

High-Voltage Operation, $V_S = \pm 4\text{ V to } \pm 18\text{ V}$ ($V_S = +8\text{ V to } +36\text{ V}$)

At $T_A = +25^\circ\text{C}$, $R_L = 10\text{ k}\Omega$ connected to $V_S / 2^{(1)}$, and $V_{CM} = V_{OUT} = V_S / 2^{(1)}$, unless otherwise noted.

PARAMETER	CONDITIONS	MIN	TYP	MAX	UNIT
NOISE					
e_n	Input voltage noise	f = 0.1 Hz to 10 Hz		250	nV _{pp}
		f = 0.1 Hz to 10 Hz		40	nV _{rms}
	Input voltage noise density	f = 1 kHz		8.8	nV/ $\sqrt{\text{Hz}}$
i_n	Input current noise density	f = 1 kHz		7	fA/ $\sqrt{\text{Hz}}$
FREQUENCY RESPONSE					
GBW	Gain-bandwidth product			2	MHz

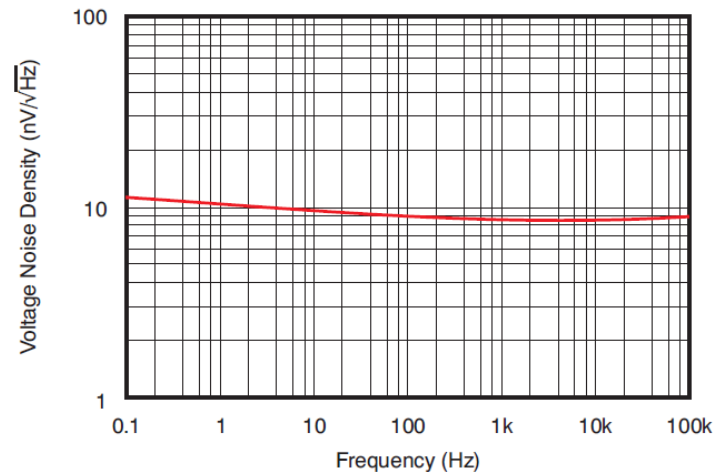
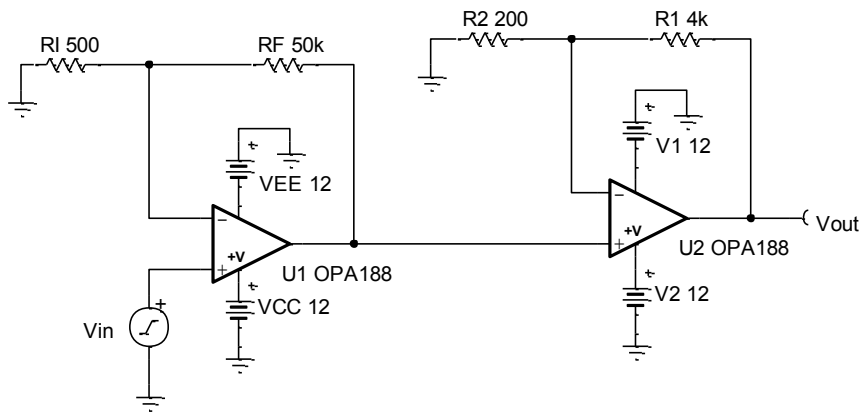

Figure 18. INPUT VOLTAGE NOISE SPECTRAL DENSITY vs FREQUENCY

Noise 4

Solutions

TI Precision Labs – Op Amps



1. Is current noise or voltage noise dominant for the circuit below?

$$R_{eq} = R_f || R_1 \approx 100\Omega$$

$$e_{ni} = R_{eq} \cdot i_n = (100\Omega)(1.5 \text{ fA}/\sqrt{\text{Hz}}) = 300 \text{ fV}/\sqrt{\text{Hz}} \text{ or } 0.00015 \text{ nV}/\sqrt{\text{Hz}}$$

$$5.5 \text{ nV}/\sqrt{\text{Hz}} \gg 0.00015 \text{ nV}/\sqrt{\text{Hz}} \quad \Leftrightarrow \quad e_{nv} \gg e_{ni}$$

Thus voltage noise is dominant

2. Is 1/f or broadband dominant?

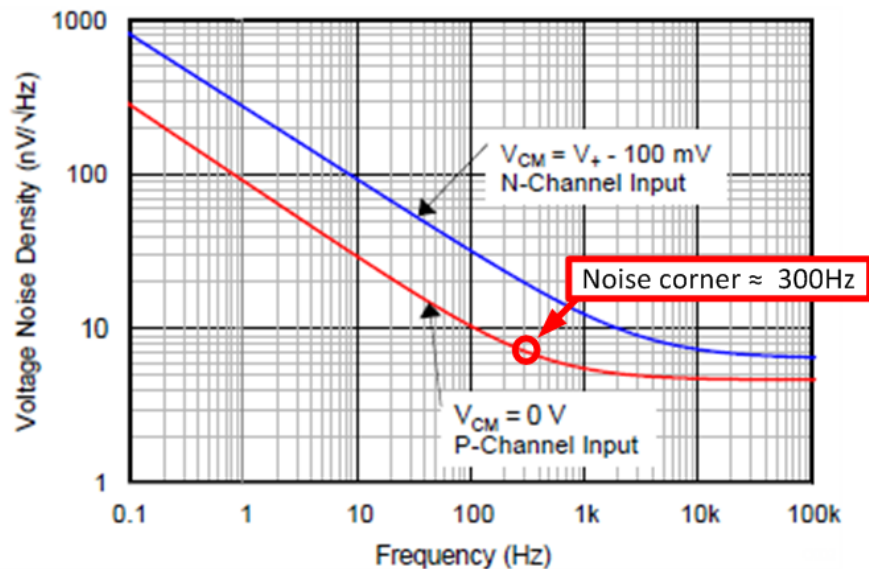

Figure 17. INPUT VOLTAGE NOISE SPECTRAL DENSITY vs FREQUENCY

$$G_n = \frac{R_f}{R_1} + 1 = \frac{20\text{k}\Omega}{100\Omega} + 1 = 201$$

$$f_c = \frac{\text{GBW}}{G_n} = \frac{10\text{MHz}}{201} = 49.8\text{kHz}$$

$$\text{BW}_n = K_n \cdot f_c = (1.57)(49.8\text{kHz}) = 78.2\text{kHz}$$

$$78.2\text{kHz} \gg 300\text{Hz} \quad \Leftrightarrow \quad \text{BW}_n \gg f_f$$

Thus broadband noise is dominant

3. Is resistor or op amp voltage noise dominant?

Refer to the data sheet table. Notice that the op amp voltage noise is dependent on common mode voltage. $V_{cm} = 0V$ in this example, so noise is $5.5nV/\sqrt{rtHz}$. The equivalent feedback resistance is approximately 100Ω , so using the chart below the resistor noise is $2nV/\sqrt{rtHz}$.

$1.3nV/\sqrt{rtHz} \times 3 = 3.9nV/\sqrt{rtHz}$

(apply Rule 1)

$5.5nV/\sqrt{rtHz} \gg 1.3nV/\sqrt{rtHz}$

(op amp voltage noise is dominant)

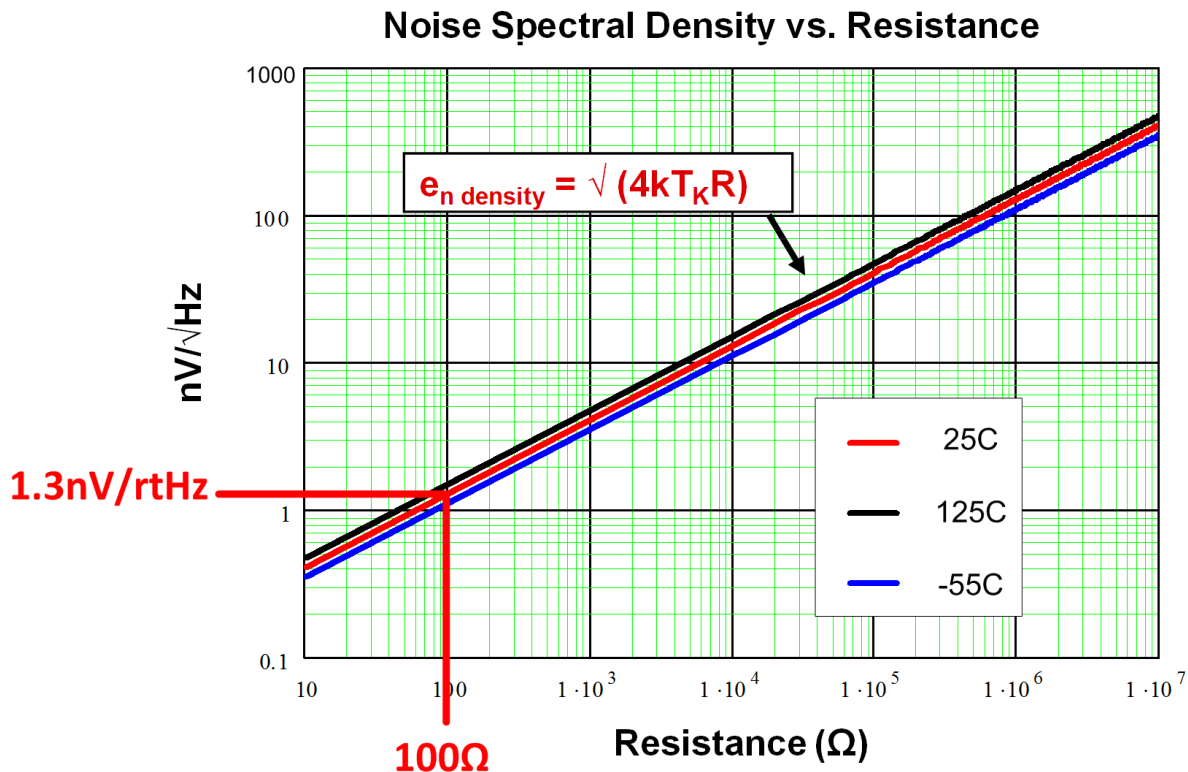

4. Calculate the total noise using appropriate simplifications.

$$G_n = \frac{R_f}{R_1} + 1 = \frac{20\text{k}\Omega}{100\Omega} + 1 = 201$$

$$f_c = \frac{\text{GBW}}{G_n} = \frac{10\text{MHz}}{201} = 49.8\text{kHz}$$

$$\text{BW}_n = K_n \cdot f_c = (1.57)(49.8\text{kHz}) = 78.2\text{kHz}$$

$$E_n = (G_n)(e_n)\sqrt{\text{BW}_n} = (201)(5.5 \text{ nV}/\sqrt{\text{Hz}})\sqrt{(78.2\text{kHz})} = 309\mu\text{V rms}$$

$$E_{npp} = 6E_n = 6(309\mu\text{V rms}) = 1.85\text{mVpp}$$

5. Is current noise or voltage noise dominant for the circuit below?

$$R_{eq} = R_f || R_1 \approx 1k\Omega$$

$$e_{ni} = R_{eq} \cdot i_n = (1k\Omega)(1.7 \text{ pA}/\sqrt{\text{Hz}}) = 1.7 \text{ nV}/\sqrt{\text{Hz}}$$

$$e_{nv} = 1.1 \text{ nV}/\sqrt{\text{Hz}} \text{ and } e_{ni} = 1.7 \text{ nV}/\sqrt{\text{Hz}} \Rightarrow e_{nv} \not\gg e_{ni}$$

$e_{nv} \approx e_{ni} \Rightarrow$ Thus both voltage noise and current noise need to be considered

6. Is 1/f or broadband dominant?

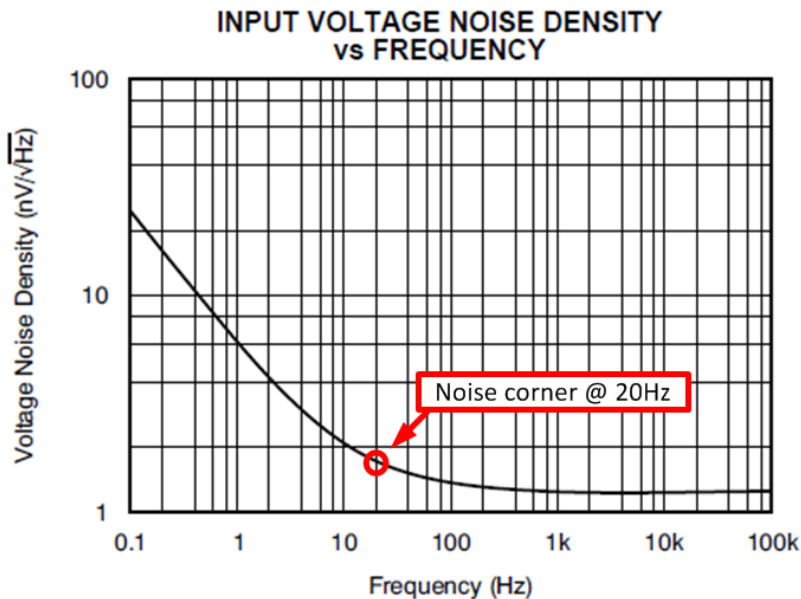

$$G_n = \frac{R_f}{R_1} + 1 = \frac{99k\Omega}{1k\Omega} + 1 = 101$$

$$f_c = \frac{GBW}{G_n} = \frac{80\text{MHz}}{101} = 792\text{kHz}$$

$$BW_n = K_n \cdot f_c = (1.57)(792\text{kHz} *) = 1.24\text{MHz}$$

$$1.24\text{MHz} \gg 20\text{Hz} \Rightarrow BW_n \gg f_f$$

Thus broadband noise is dominant

7. Is resistor or op amp voltage noise dominant?

$$e_n = 1.1\text{nV}/\sqrt{\text{rtHz}} \quad (\text{op amp noise})$$

$$e_{nr} = 4\text{nV}/\sqrt{\text{rtHz}} \quad (\text{resistor noise})$$

$$4\text{nV}/\sqrt{\text{rtHz}} \times 3 = 12\text{nV}/\sqrt{\text{rtHz}} \quad (\text{apply Rule 1})$$

The op amp noise needs to be greater than $12\text{nV}/\sqrt{\text{rtHz}}$ to be dominant.

In this case, resistor noise dominates $e_{nr} \gg e_n$

Normally, it is recommended to reduce the feedback impedance to ensure that the op amp noise dominates. The only concern is that lower feedback impedances translate to larger output current requirements.

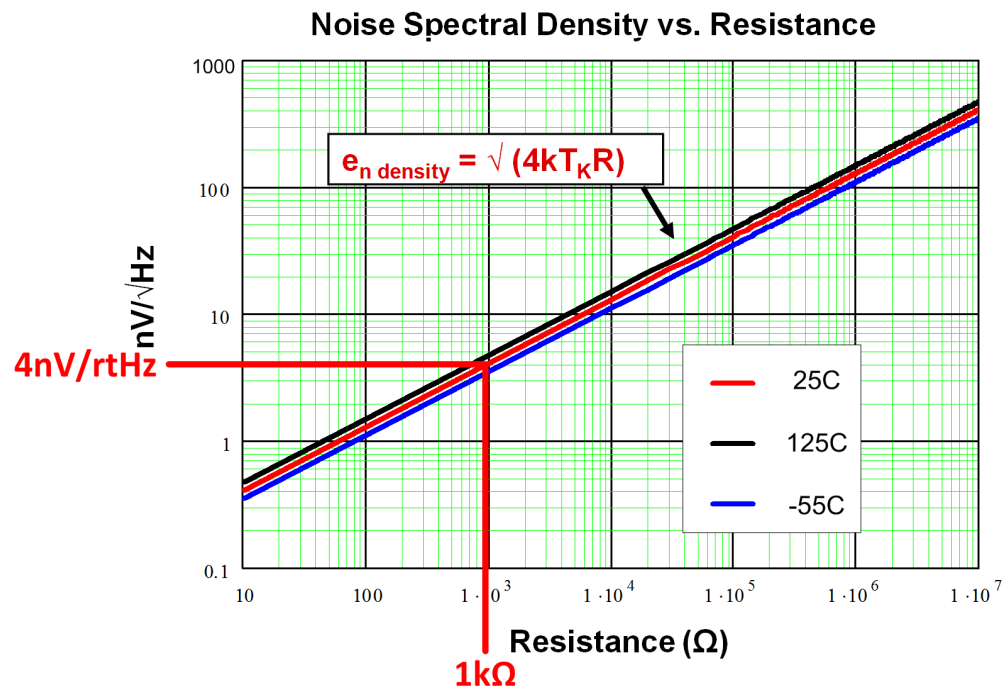

8. Calculate the total rms noise at the output.

$$e_{ni} = 1.7 \text{ nV}/\sqrt{\text{Hz}}$$

$$e_{nr} = 4 \text{ nV}/\sqrt{\text{Hz}}$$

$$e_{nv} = 1.1 \text{ nV}/\sqrt{\text{Hz}}$$

$$e_{n_tot} = \sqrt{e_{ni}^2 + e_{nr}^2 + e_{nv}^2} = \sqrt{(1.7)^2 + (4)^2 + (1.1)^2} = 4.5 \text{ nV}/\sqrt{\text{Hz}}$$

$$E_{n_tot} = (G_n)(e_{n_tot})\sqrt{BW_n} = (100) \left(\frac{4.5 \text{ nV}}{\sqrt{\text{Hz}}} \right) \sqrt{1.24 \text{ MHz}} = 501 \mu\text{V rms}$$

9. Is the input or output stage dominant?

The input stage and the output stage both use the same amplifier. This makes the comparison easy. If a higher noise amplifier were used in the output stage more calculations may be required. In this case, just look at the first stage gain. If it is greater than 3 than the input stage will be dominant (Rule 1). In this case the noise gain of the input stage is 101, so the input stage is dominant. In subsequent calculation we will only consider the input stage. The gain of the output stage only need be considered to calculation the output noise. The noise sources in the second stage are ignored.

Note: In some cases the noise from the second stage may play a role if the bandwidth of the second stage is significantly wider than the first stage. In this case a Cf filter may be advisable.

10. Is current noise or voltage noise dominant for the circuit below?

$$R_{eq} = R_f || R_1 \approx 500\Omega$$

$$e_{ni} = R_{eq} \cdot i_n = (500\Omega)(7 \text{ fA}/\sqrt{\text{Hz}}) = 0.0035 \text{ nV}/\sqrt{\text{Hz}}$$

$$e_{nv} = 8.8 \text{ nV}/\sqrt{\text{Hz}} \text{ and } e_{ni} = 0.0035 \text{ nV}/\sqrt{\text{Hz}} \Rightarrow e_{nv} \gg e_{ni}$$

Op amp voltage noise is dominant

11. Is 1/f or broadband dominant?

This is a trick question. The OPA188 is a zero drift amplifier and does not have 1/f noise. Notice that the spectral density curve is relatively flat down to 0.1Hz. So in this case broadband is definitely dominant because there is no 1/f noise.

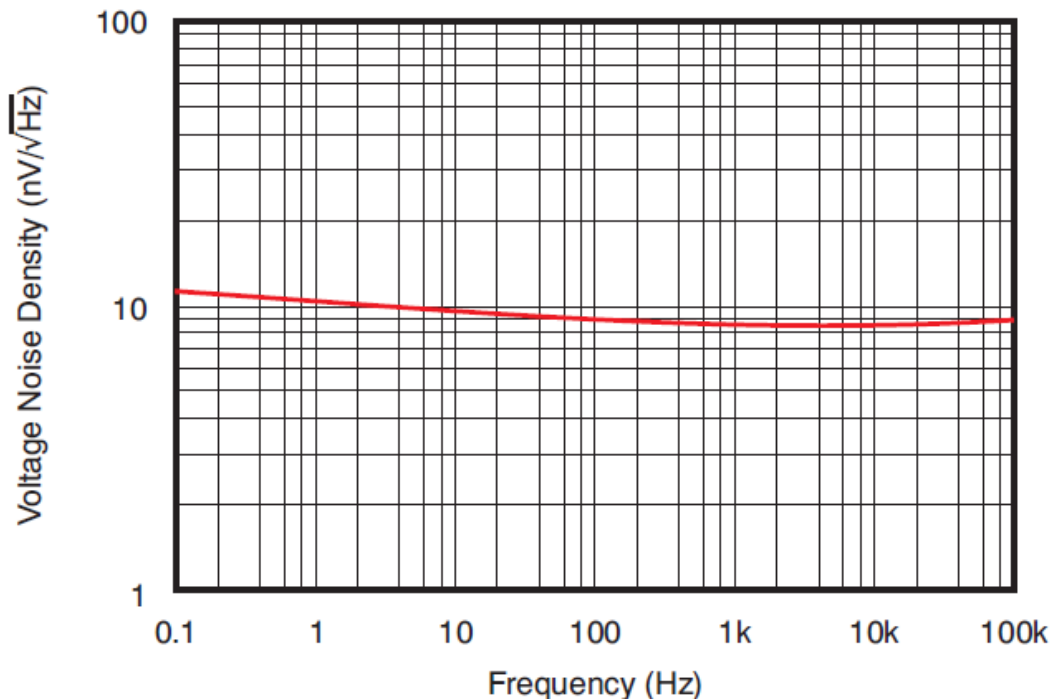

Figure 18. INPUT VOLTAGE NOISE SPECTRAL DENSITY vs FREQUENCY

12. Is resistor or op amp voltage noise dominant?

Op amp noise is 8.8nV/rtHz. The equivalent feedback resistance is approximately 500Ω, so using the chart below the resistor noise is 3nV/rtHz.

$3\text{nV}/\text{rtHz} \times 3 = 9\text{nV}/\text{rtHz}$ (apply Rule 1)

$8.8\text{nV}/\text{rtHz} \gg 3\text{nV}/\text{rtHz}$ (Op amp noise almost dominant)

Technically the op amp noise is not quite 3x the resistor noise. However, it's close so let's assume that it's dominant. In a real world design you might further reduce the feedback. However, you don't need to reduce much.

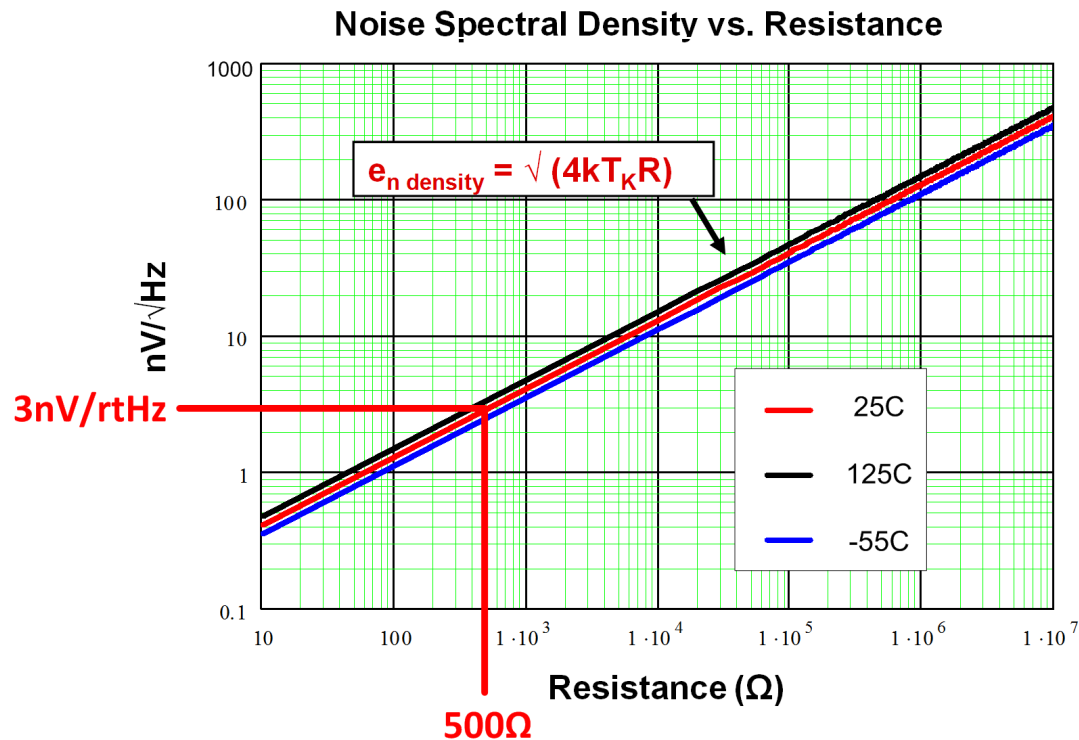

13. Calculate the total noise using appropriate simplifications.

$$G_{n1} = \frac{R_f}{R_1} + 1 = \frac{50\text{k}\Omega}{500\Omega} + 1 = 101$$

$$G_{n2} = \frac{R_f}{R_1} + 1 = \frac{4\text{k}\Omega}{200\Omega} + 1 = 21$$

$$f_{c1} = \frac{\text{GBW}}{G_n} = \frac{2\text{MHz}}{101} = 19.8\text{kHz}$$

$$\text{BW}_n = K_n \cdot f_c = (1.57)(19.8\text{kHz}) = 31.1\text{kHz}$$

$$E_n = (G_{n1})(G_{n2})(e_n)\sqrt{\text{BW}_n} = (101)(21)(8.8 \text{ nV}/\sqrt{\text{Hz}})\sqrt{(15.6\text{kHz})} = 3.30\text{mV rms}$$

$$E_{npp} = 6E_n = 6(4.64\text{m} * \text{V rms}) = 27.8\text{mVpp}$$